

Quick Exhaust Valve

Hydraulic

1/2" FEMALE NPT, 6,000 PSI W/SPRING

Model 13QS40 Std / 13QS41 NACE / 13QS80 -55F Service

Conforms to the SEP category of the European Pressure Equipment Directive
Issue No. 97/23/EC

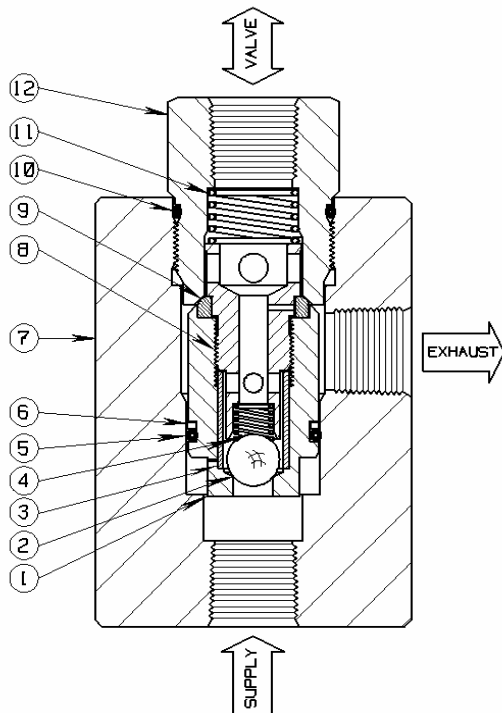

The **13QS40/41/80** is a two position, **6,000** PSI poppet operated **high flow exhaust** control valve assembly. It establishes flow from the Supply to Valve (inlet to outlet) connections to open a Surface Safety Valve (SSV or hydraulic Actuator) automatically with each application of operating pressure.

A loss or significant decrease of supply pressure will unseat the Poppet quickly to establish high volume, reverse or Exhaust flow. Rapid closure of an Actuator valve is assured with the use of a Quick Exhaust Valve.

The 13SQ40 Quick Exhaust Valve utilizes a small internal orifice that bypasses the Poppet assembly to provide thermal expansion capability. It also minimizes the effects of pump cycling or small volume fluid leaks, to maintain proper operating volume or pressure. A special spring (Item 11) provides additional exertion force on the Poppet assembly to overcome residual backpressure, which can be disruptive for certain types of hydraulic actuators.

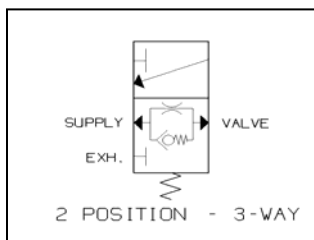

PARTS LIST:

- | | |
|-------------------------|-----------------|
| 1. Valve Poppet | 7. Valve Body |
| 2. Ball * | 8. Seal Guide |
| 3. Restriction Sleeve * | 9. Kel-F Seat * |
| 4. Spring * | 10. O Ring * |
| 5. O Ring * | 11. Spring * |
| 6. Back Up Ring * | 12. Retainer |

* Indicates parts included in a Repair Kit

Sigma Model Number 13QS40/41

1/2" FEMALE NPT, 6,000 PSI W/SPRING

Product Specifications

Flow Control Application / Operation: Quick Exhaust / Automatic (No operator intervention required)

Control Function: Spring Biased Poppet Operated

Flow Capacity: High Flow Service

Pressure Rating Body (Control Ports): 6,000 PSI maximum (413 bar)

Seal Material: Viton and Kel-F

Connection Size (Body): 1/2-14 Female N.P.T. (Supply, Valve, Exhaust)

Wetted Component Material (Metal): 316 Stainless Steel and 17-4PH SS

Mounting: Field Mount (Standard)

Orifice: .718 Diameter **Cv Factor:** 4.33

Weight: 5 Lbs.

Operating Temperature: Standard and NACE -20° F to +250° F (-29° C to +121° C)
Arctic -55 F to +200 F

Overall Dimensions: 5-1/8 Height x 2 3/8 Diameter (13.02 cm Height x 7.3 cm Diameter)

Pressure Equipment Directive (PED): This product conforms to the SEP Category of the European P.E.D.

Installation and Instructions:

Install between the interface valve and the actuator. This is done by threading the pipe or fitting from the control system into the port labeled "Supply". The piping from the actuator is threaded into the port labeled "Valve". The piping from the hydraulic fluid reservoir is threaded into the port labeled "Exhaust". A significant loss in pressure within the control system will trigger an exhaust of the actuator through the valve port and out the exhaust port. Sigma recommends the use of appropriate thread sealant for each port connection.

Maintenance : No routine maintenance is required for normal service conditions where hydraulic fluid is maintained to standard system requirements.

Shelf Position Port Status

Supply Inlet	Instrument supply pressure open to cylinder (Actuator)
Valve	Outlet Pressure to cylinder (Closed to Exhaust Port)
Exhaust	Depressurizes cylinder upon loss of Supply Inlet