

		MESSRS.	
REV. DATE	DESCRIPTION		
		<p>LINE FAULT DETECTOR & EM'CY TRIPPING CONTROL FOR MARINE & INDUSTRIAL (LFD - □PB[®] Series)</p>	
		<p>LFD - □PB[®]</p> <p>└─ output ─┬─ 3 : 3 Point 6 : 6 Point 10 : 10 Point</p>	
		7 SHEETS WITH COVER	
		CLASS	BV
		APPROVED BY	C. G. CHOI
		CHECKED BY	C. G. YI
		DESIGNED BY	M. R. JANG
DATE	2008. 03. 25		
DRAW No.	T283-2500		

LINE FAULT DETECTOR (LFD-□PB® Series)

CONTENTS

Sheet No.

1. General information	-----	2
1) General		
2) Ordering information		
2. Specifications of construction & environment	-----	3
2.1 Case		
2.2 External connection T.B		
2.3 Front name plate		
2.4 Outside figure & Mounting		
2.5 Ambient conditions		
2.6 Vibration test		
3. Specifications of electrical rating	-----	4
3.1 Aux. power voltage rating		
3.2 Aux. power voltage variation		
3.3 Input signal		
3.4 Output signal		
3.5 Line fault alarm delay time		
3.6 2ndary alarm recovery time		
3.7 Insulation resistance		
3.8 Surge transient		
4. Descriptions	-----	4
5. Connection & T.B Layout	-----	5
6. Application circuit	-----	6
1) Em'cy stop for tripping		
2) In case of em'cy stop line is fault		
3) Recovery		
4) Alarm timing flowchart		
5) System diagram		

LINE FAULT DETECTOR (LFD-□PB® Series)

1. GENERAL INFORMATION

1) GENERAL

LINE FAULT DETECTOR continuously monitors whether the line of emergency stop system, that applies to marine system, power plant, steel, chemical plant and other industrial system, is faulted or not. It's a essential equipment to prevent accident spreading due to the breakage of emergency stop line when abnormal condition of a system requires emergency state.

2) ORDERING INFORMATION

The following models are applied according to the specification of a control system.

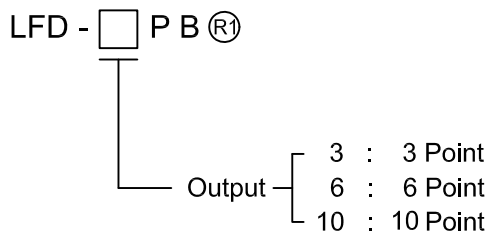

LINE FAULT DETECTOR (LFD-□PB® Series)

2. SPECIFICATIONS OF CONSTRUCTION & ENVIRONMENT

2.1. CASE

- 1) Material : PC(polycarbonate) - Flame retardant (UL94 V-O)
 - TRIREX3025G10 / Glass fiber reinforced
 - Dielectric strength : 31KV/mm (ASTM D149 / IEC 243)
- 2) Color : Terminal block part - Blue
 - Front - Ivory , Body - Black (maker standard)

2.2. EXTERNAL CONNECTION T.B

- 1) Material
 - Insulation Material : PA / UL94 V-O
 - Terminal : CnZn
- 2) Screw size : M3
- 3) Spacing : 5mm
- 4) Rated Voltage : 250V (UL 1059, EN60998)
- 5) Wire Size (max.) : AWG 22-14 (2.5 SQ)
- 6) Test Voltage : 2.0kV
- 7) Rated Torque : 0.5Nm

2.3. FRONT NAME PLATE : Screen Print

2.4. OUTSIDE FIGURE & MOUNTING (unit in mm)

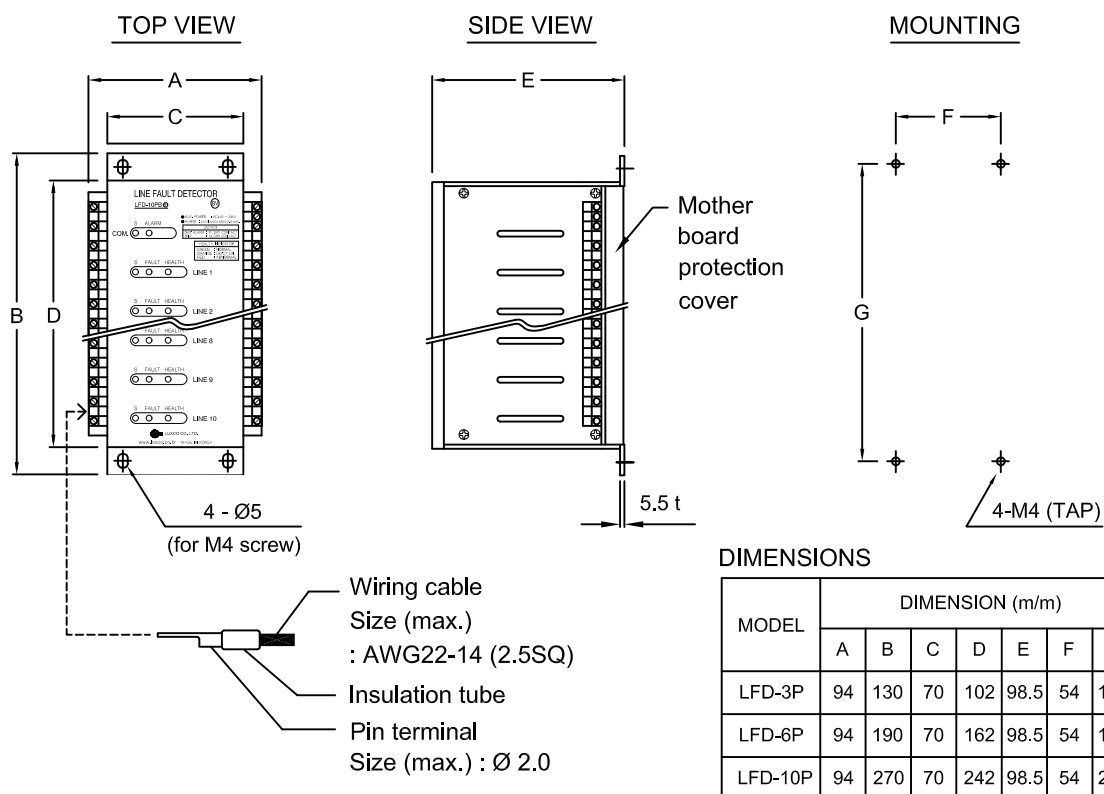

2.5. AMBIENT CONDITIONS

- 1) Ambient temperature range : -10°C ~ +60°C
- 2) Storage temperature range : -20°C ~ +70°C
- 3) Humidity : 20% ~ 90% R.H

2.6. VIBRATION TEST : 30 Hz for 2 hours (acceleration : ±0.7G)

LINE FAULT DETECTOR (LFD-□PB® Series)

3. SPECIFICATIONS OF ELECTRICAL RATING

- 3.1 AUX. POWER VOLTAGE RATING : AC100 ~ 240V 0.25A(max) 50 / 60Hz
- 3.2 AUX. POWER VOLTAGE VARIATION : 85%~110%
- 3.3 INPUT SIGNAL
 - 1) Type : "a" contact with resistor 1/2W 1K ohm for 1 circuit
 - 2) Leakage Current : Below 10mA per each point
 - 3) Cable Length : Within 500M (Above 1.25 SQ)
- 3.4 OUTPUT SIGNAL
 - 1) 2ndary Alarm Output : "1c" dry contact (30VDC 1A / 125VAC 0.5A, p.f=1)
 - 2) Tripping Contact : "1a" dry contact (30VDC 5A / 250VAC 5A, p.f=1)
- 3.5 LINE FAULT ALARM DELAY TIME : 2.5 Sec (±0.1 Sec)
- 3.6 2NDARY ALARM RECOVERY TIME : 2.5 Sec (±0.1 Sec)
- 3.7 INSULATION RESISTANCE : Above 200Megger ohms between live part and enclosure
- 3.8 SURGE TRANSIENT : 1kV 50uVs line/line, 0.5kV 50kV 50uVS line/line
(IEC 1000-4-5 / 1995)

4. DESCRIPTIONS

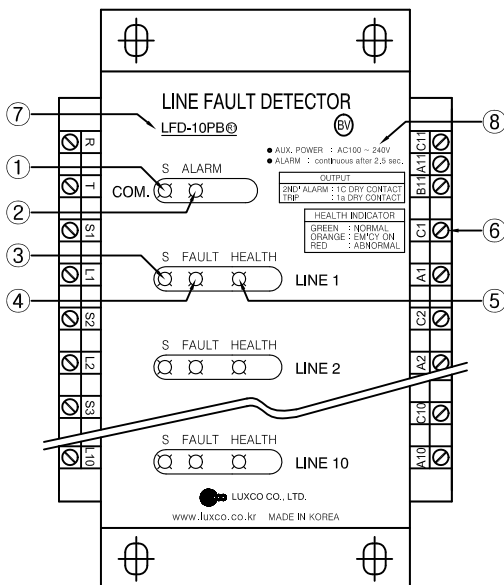

- ① Common Source indicator : 3 Ø LED (light up in green)
- ② 2ndary alarm indicator : 3 Ø LED (light up in yellow)
- ③ Line Source indicator : 3 Ø LED (light up in white)
- ④ Line fault indicator : 3 Ø LED (light up in red)
- ⑤ Health indicator : 3 Ø LED

GREEN : NORMAL
 ORANGE : EM'CY ON
 RED : ABNORMAL
 (Detect card fail)

- ⑥ External connection T.B : (UL-1059, EN60998)
- ⑦ Model Name
- ⑧ Rating

- AUX. POWER : AC100 ~ 240V
- ALARM : Continuous after 2.5 sec.

OUTPUT	
2ND' ALARM	: 1C DRY CONTACT
TRIP	: 1a DRY CONTACT

LINE FAULT DETECTOR (LFD-□PB® Series)

5. CONNECTION & T.B LAYOUT

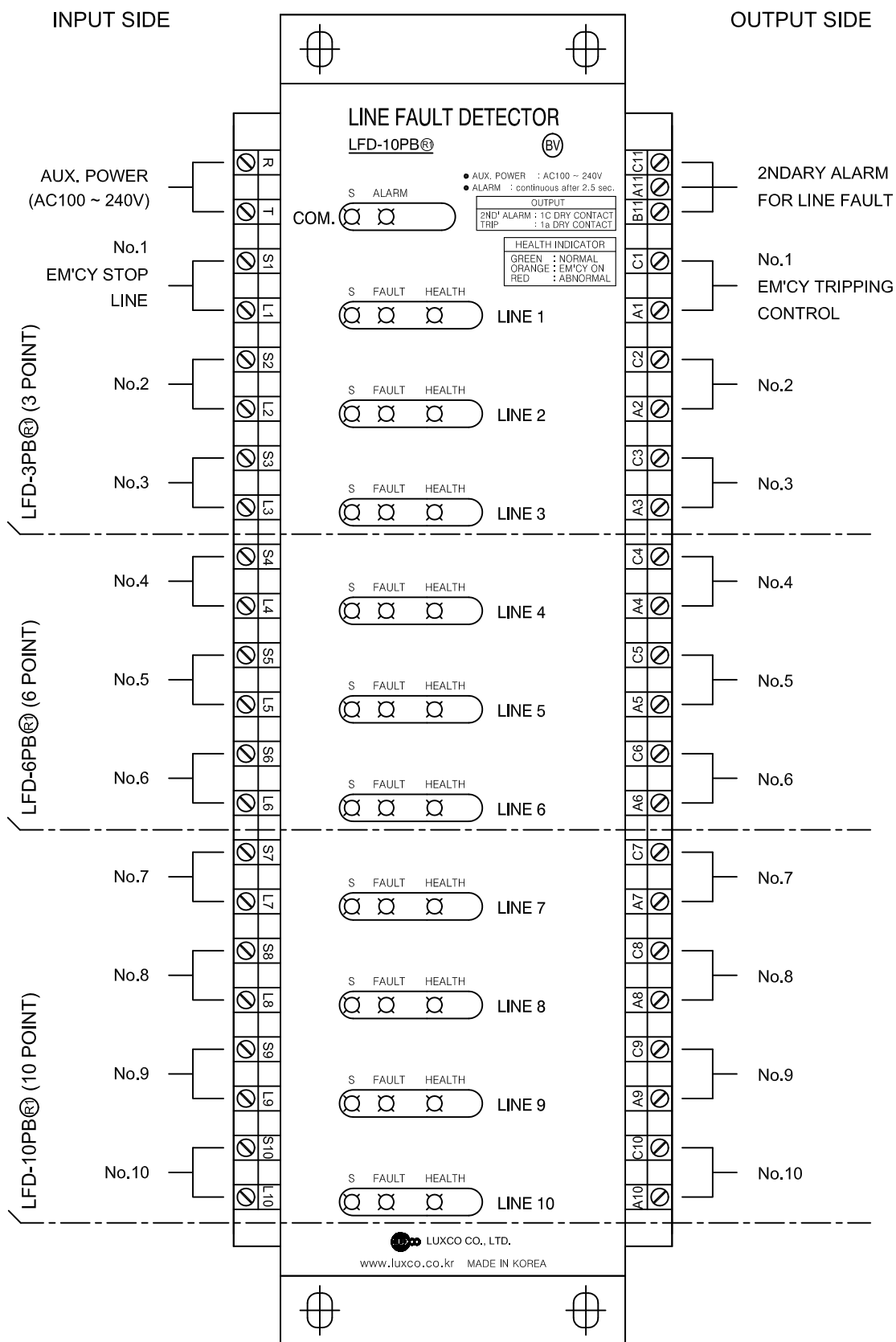

LINE FAULT DETECTOR (LFD-□PB® Series)

6. APPLICATION CIRCUIT

1) EM'CY STOP FOR TRIPPING

MCCB (MCCB 1~MCCB n) is tripped by each control card when an em'cy switch line is in normal condition and em'cy stop button is pressed.

2) IN CASE OF EM'CY STOP LINE IS FAULT

In case that em'cy stop line is fault, the alarm goes out to the system via the T.B #(c11, a11, b11) after 2.5 sec and individual alarm lamp of control card is lit up on steady.

On keeping 1'st abnormal alarm, if another line is faulted, the 2ndary alarm come out again continuously from common card after 2.5 sec of delay.

3) RECOVERY

After the line recovers from fault situations, detector circuit is automatically recovered and turn to normal condition.

4) ALARM TIMING FLOWCHART

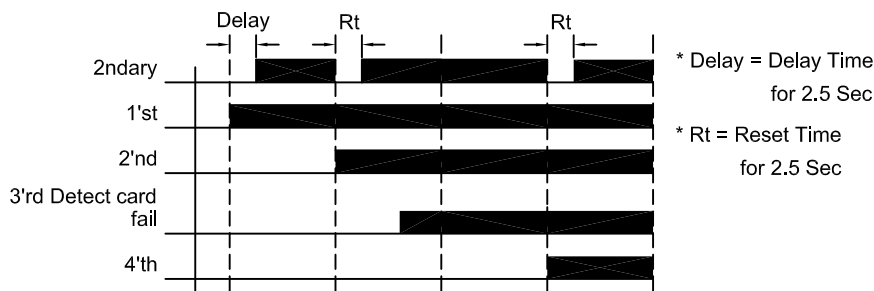

5) SYSTEM DIAGRAM

